

Class 300 • Union Bonnet* • Rising Stem • Threaded Ends

Gate Valve Figure B-144

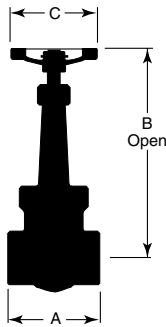
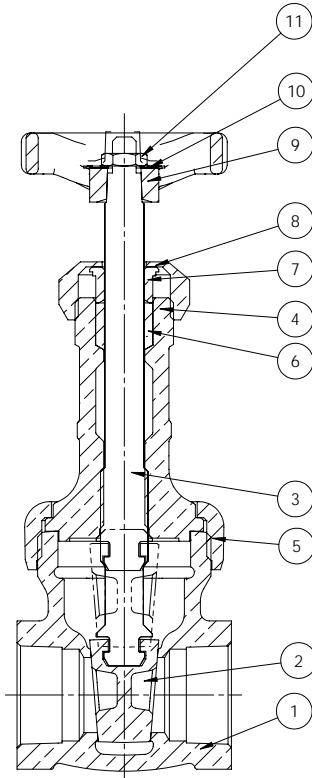

Materials of Construction

No.	Description	Material	ASTM Spec.
1	Body	Bronze	B-61 C92200
2	Disc	Bronze	B-61 C92200
3	Stem	Bronze	B-371 C69400
4	Bonnet	Bronze	B-61 C92200
5	Union Bonnet Ring	Bronze	B-61 C92200
6	Packing	Graphite (Asbestos Free)	
7	Gland	Brass	B-16 H02
8	Packing Nut	(1/4" - 1 1/2") Brass	B-16 H02
		(2" - 3") Brass	B-61 C92200
9	Handwheel	Ductile Iron	
10	ID Plate	Aluminum	
11	Lock Nut	Steel Cadmium	

NOTE:

The addition of the letter "K" at the end of the figure number designates valves assembled & tested in the USA. Materials of Construction & Dimensions are the same.

Industry Standards

Complies with MSS SP-80 Type 2

See Page 6 for Pressure-Temperature Ratings

Dimensions and Weights

Inches (millimeters) - Pounds (kilograms)

Valve Size	Dimensions			Wt.
	B	C	A	
1/4	4.65	2.25	1.64	0.79
	(118)	(57)	(42)	(0.36)
3/8	4.65	2.25	1.64	0.77
	(118)	(57)	(42)	(0.35)
1/2	5.37	2.75	2.10	1.28
	(136)	(70)	(53)	(0.58)
3/4	6.56	2.75	2.14	1.85
	(167)	(70)	(54)	(0.84)
1	7.60	2.75	2.47	2.99
	(193)	(70)	(63)	(1.36)
1 1/4	9.09	4.00	3.08	4.40
	(231)	(102)	(78)	(2.00)
1 1/2	10.24	4.00	3.21	5.46
	(260)	(102)	(82)	(2.48)
2	12.14	4.00	3.47	9.70
	(308)	(102)	(88)	(4.41)
*2 1/2	14.65	4.75	4.25	14.83
	(372)	(121)	(108)	(6.74)
*3	16.81	5.50	4.59	22.07
	(427)	(140)	(117)	(10.03)

* 2 1/2" and 3" have Bolted Bonnet